

Commercial Nickel Cadmium Batteries for Space Use: A Proven Alternative for LEO Satellite Power Storage.

Craig S. Clark, Alan D. Hill and Martin Day.
Surrey Satellite Technology Limited,
Centre for Satellite Engineering Research, University of Surrey,
Guildford, Surrey, GU2 5XH, U.K.
Telephone: +44 1483 259278
Fax: +44 1483 259503
email: c.clark@ee.surrey.ac.uk

ABSTRACT

For the past 14 years, satellite engineers at Surrey have successfully applied commercially available Nickel Cadmium (NiCd) batteries to Low Earth Orbit (LEO) Microsatellite and Minisatellite programmes. Details of the commercial cell battery's flight heritage, as well as flight data taken from microsatellites in a variety of different orbital and thermal environments, will validate the success of SSTL's battery screening and matching techniques. In particular, one spacecraft's battery has performed some 70,000+ charge/discharge cycles over a 14 year period and is still providing a useful function.

A carefully engineered commercial cell battery, screened rigorously and used within a controlled charge / discharge regime, is capable of providing a low cost, reliable product. With many spacecraft manufacturers taking a substantial interest in the smaller, faster, cheaper approach to spacecraft production, the evidence in this paper will make it difficult to justify the budget and schedule implications required for fully qualified aerospace batteries.

Key Words: Nickel Cadmium, Batteries, Commercial-off-the-shelf components.

1. INTRODUCTION

At a time when the space industry is being forced to evaluate traditional spacecraft engineering techniques, contending with the massive budgets and lengthy concept to launch project timescales, many space companies are looking towards the smaller, faster, cheaper approach of spacecraft engineering.

A classic example of this spacecraft engineering philosophy is SSTL's battery programme. Surrey

have been producing batteries for low earth orbit satellites for over 15 years. What is unique about the battery is the fact that commercial nickel cadmium cells are used, and not space grade cells.

A battery using commercial cells can be produced at a reduced cost, but may be more importantly, at a greatly reduced delivery time. Once the cells have been purchased from a local distributor, all testing and manufacture of the battery can be performed in house. This gives the advantage of, not only dictating the battery production time, but also having total quality and process control over the battery testing and manufacture.

The success story of the commercial cell battery is demonstrated by the nine low earth orbit satellites which, between them, have accumulated over half a century's worth of in-orbit operation, using commercial cell batteries, with an impressive zero failures record.

2. THE COMMERCIAL CELL

The cells which have been used by SSTL over the past 15 years of satellite design, have been the same as those found in applications such as video cameras, power tools and remote control cars, for example. They are cylindrical, sealed, nickel cadmium F-cells and can easily be purchased from local distributors. The only difference between the cells that are used in your hammer action power drill and the spacecraft power system is the extensive tests that are performed on every cell prior to being launched into orbit.

The cell type that has been used most extensively as part of SSTL's spacecraft power system is the GATES Gold-top F-Cell. The Gold-Top F-Cell was a high temperature cell, with an operating temperature range of 0°C to 70°C, a nominal cell voltage of 1.2V and a rated capacity of 6Ah [1]. The production of these cells ceased following the take-over of the commercial arm of GATES by Energizer. It was then necessary for SSTL to find a

replacement for what had been a very successful cell.

The chosen replacement for the GATES cell was the SANYO CADNICA KR-7000F. As a result of extensive tests performed on F-cells from various manufacturers, it was the KR-7000F that proved to be the most suitable candidate for use in our application.

The KR-7000F is from SANYO's standard range of NiCd cells, which are intended for applications where the battery will experience frequent charge/discharge cycles. The KR-7000F has a rated capacity of 7Ah and a nominal voltage of 1.2V [2]. The cell has a safety vent on its positive end, which will vent electrolyte in the event of excessive pressure build-up within the cells. Each of the safety vents are individually tested by SANYO, prior to assembly with the rest of the cell, to ensure that they operate at the correct pressure. The operating temperature range of the KR-7000F is 0°C to 45°C, which is considerably less than the GATES cell. In flight has shown that the battery temperature rarely exceeds 30°C, reducing the need for the high temperature type cell. The SANYO cell has an excellent record for reliability in terrestrial applications, and SSTL plan to prove that this will also be the case in a space application [3]

3. BATTERY ACCEPTANCE TESTS

The test regime adopted by SSTL was originally based on standard aerospace nickel cadmium battery acceptance test procedures [4] and adapted for the testing of commercial nickel cadmium cells.

Due to the fact that the cells are outside SSTL's quality control procedures during their manufacture, and also because they are intended for commercial purposes, it is important that the cells are thoroughly screened prior to selection for use in the flight battery pack. With this in mind, most of the tests are performed on the battery at a cell level. These tests include both electrical and mechanical tests and are designed to verify the specified electrical performance and mechanical integrity.

During the cell level tests, the charge and discharge profiles of each cell are measured over different temperatures. This information can then be used to select a set of matched cells for use in the flight battery.

The result of such screening tests are acceptance levels of some 80% or more. The majority of failures being only minor deviations from the nominal specification. It is also interesting to note that there has yet to be a cell that has failed outright.

3.1 Cell Level Mechanical Tests

Tagging of Cells - Due to the cells being of a cylindrical design, the positive and negative terminations are in the form of spot welded solder tags. During the spot welding process, pull tests are performed on sacrificial cells at regular intervals to confirm correct set-up of the welding machine. Every tag is then inspected to check that the weld is sound.

Visual Inspection - The plastic sleeving is removed from the cells and the steel casings are inspected for any signs of physical damage or corrosion. A further inspection is performed later in the acceptance test programme.

Vibration and X-Ray - In order to confirm their internal mechanical integrity, the cells are vibrated, in the axial and radial axes, to an acceptance level. Radiological examinations are taken before and after the vibration, which are then compared to determine any movement within the cell structure.

Weight Measurement - The weight of the cell is measured and noted for comparison against the result of a second measurement at the conclusion of the electrical tests. The test is intended to highlight any significant reduction in the mass.

3.2 Cell Level Electrical Tests

The electrical tests performed on the cells are fully automated. This is achieved by using an in-house designed, computer controlled, Battery Test Facility (BTF). The BTF software also interfaces with a thermal chamber in which the four racks of 10 series connected cells are housed. This allows the automation of the chamber temperature control, and hence tests over temperature.

The electrical tests consist of:

Initial charge - A gentle first charge is given to each cell.

Stabilisation cycles - These cycles condition the cells for operation in the environment in which they are intended to be used.

Overcharge tests - To verify the cell's overcharge protection. Also, cells are most likely to vent under overcharge as the internal pressure increases.

Capacity measurements - To ensure that the cell meets with the manufacturer's specifications. Capacity at different temperatures is also important as this can vary widely.

Weld test - A high current discharge will check the integrity of the cells internal welding.

Charge Retention test - To check for internal short circuits or low resistance paths

Electrolyte leakage test - Each cell is tested to ensure that the cell vent has not operated, leaking electrolyte.

The voltage, current and temperature are regularly sampled throughout all of the tests, providing the information required to calculate capacity values and to determine charge and discharge characteristics. Each cell's test results are examined to determine whether the cell has passed or failed the criteria required for the flight cells. All the cells that pass will be used in the matching process to optimise selection of a flight batch.

3.3 Cell Matching

The cell capacity matching is performed by hand, and any cells that have a capacity which deviates considerably from the average cell capacity will be rejected. This leaves only cells with close capacity characteristics.

The information obtained from the electrical tests is then used to match the voltage characteristics of the cells. The BTF information for each of the cells is fed into voltage matching software, which was written in-house at SSTL. The software compares every data point of every cell and then outputs suggested combinations of matched cells and the maximum voltage deviation of their data points. The best matched group of cells will then be used in the flight battery.

3.4 Battery Level Tests

Following the fabrication of the flight battery, there are further electrical and mechanical tests which will be performed. The electrical tests consist of conditioning and characterisation cycles, and also a high-rate discharge test to check the integrity of the pack electrical connections. The battery is also vibrated to an acceptance level, but this is generally during the spacecraft vibration tests.

4. BATTERY DESIGN

The battery consists of 10 nickel cadmium cells connected in series. The housing divides the cells into two packs of 5 cells each, which are then mounted in a box, which will also house associate electronics and connectors.

The cell carriers and battery box are machined from solid aluminium blocks. As can be seen from the drawing of a battery pack in Figure 4.1, there are bore holes machined in the aluminium for the cells to be housed, and the exterior of the pack is shaped to remove unnecessary aluminium mass, optimising the weight of the pack.

Figure 4.1: Battery Pack of 5 Cells in Series.

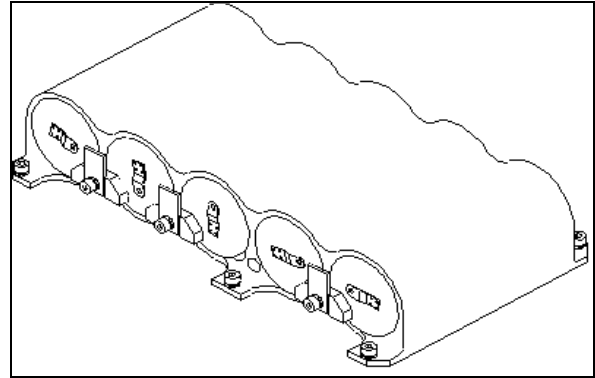

Having been tagged, cleaned and wrapped in insulating material, the cells are potted in the housing using a foam potting compound. An absorbent material can be used to contain any electrolyte leakage if this is a mission requirement. Once potted, the cells are then wired, from tag to tag, in series. The finished packs weigh approximately 1.5kg each.

At this stage, packs undergo the Battery Level Test as described in the previous section. Once these tests are complete, the packs can then be assembled into the battery box along with the Battery Charge Monitor (BCM) electronics. The BCM provides telemetry on the individual cell voltages, as well as the battery charge and discharge current telemetry. With the assembly of the battery box complete, the battery is then ready for integration with the rest of the spacecraft.

5. THE SPACECRAFT POWER SYSTEM

Although differing in component level design, the same basic power system topology has been used for all SSTL spacecraft since UoSAT 1, which was designed in the late 1970s/early '80s. The power system topology is of a centralised type and is shown in Figure 5.1.

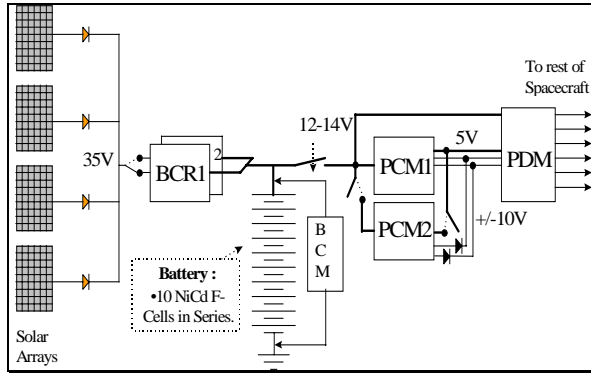

Figure 5.1: Power System Block Diagram

Primary power is supplied via 4 body mounted solar arrays (see Figure 5.2), which then feed through protection diodes and into redundant Battery Charge Regulators (BCR). The satellite around the z-axis, at approximately 1 revolution per 10 minutes, maintaining a low average solar array temperature

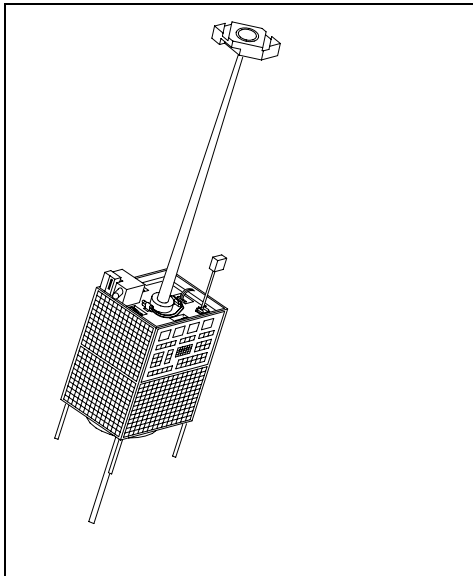

Figure 5.2: Drawing of UoSAT-5

The BCR control is temperature compensated and tracks the maximum power point of the solar arrays and battery end of charge voltage, over their expected temperature range. This ensures that the solar arrays are used to their full potential and that the battery is prevented from ever being overcharged.

The unregulated battery voltage is then fed into the Power Conditioning Module (PCM) (which has dual redundant systems) and the Power Distribution Module (PDM). The PCM converts the battery volts into a regulated 5V supply, and unregulated $\pm 10V$ supply, which is also fed into the PDM.

The PDM consists of solid state power switches and fuses, which interface the power system with the redundant bus sub-systems and payloads.

It is interesting to note that the battery is the only non-redundant item within the power system, highlighting the users confidence in the reliability of the commercial cell battery.

6. OPERATING CONDITIONS

Of course, the success of the commercial cell battery is not only due to the screening process, but also due to the treatment that that battery receives during spacecraft operations. As previously mentioned, the battery is charged via the BCR, which fast charges the battery when the solar arrays are in sunlight, but tapers off the charge current to a trickle charge level before reaching the point of overcharge. The end of charge voltage of the battery varies with temperature, so the BCR control is designed to match the temperature coefficient of the battery.

For the majority of SSTL's microsattellites, the thermal design of the spacecraft results in a battery temperature of 15°C , varying by only about 5°C per orbit during nominal operations. These benign thermal conditions are ideal to maintain a healthy battery.

Another very important factor in prolonging the cycle life of a battery is the depth of discharge. In the case of SSTL spacecraft, the depth of discharge per orbit is approximately 20%, which provides the maximum cycle life from the battery. The drawback of this, of course, is that the battery must be sized 5 times larger than is required in terms of capacity, which can be costly in mass and volume.

7. FLIGHT HERITAGE

Following the success of the University of Surrey's first spacecraft, UoSAT-1, which used a space grade battery, there was to be a follow up mission, namely UoSAT-2. Due to the obvious cost constraints of a low budget research mission, an alternative to expensive aerospace cells was required. This alternative was to be standard nickel cadmium cells available from GATES.

UoSAT-2 was launched in March of 1984, into a 750km, sun synchronous orbit and has since completed over 73,000 orbits, and hence, charge/discharge cycles, in its 14+ years of operation. The spacecraft is still operational and provides bulletins and information to amateur radio enthusiasts world wide. These figures are impressive reading for a aerospace grade battery, not to mention one which consists of commercial cells. Figure 7.1 is telemetry data, showing the battery current and voltage, taken from early 1997. From this data, it can be seen that the battery appears to still be in good health. The battery

reaches its end of charge voltage (set by the BCR) whilst the solar arrays are in sunlight, and has a discharge profile during eclipse which looks no different from telemetry retrieved from the spacecraft just after launch [5]. The depth of discharge of the battery is approximately 15%, due to the short eclipse periods. SSTL microsatellites are not capable of orbit correction, resulting in orbit shift over a period of years, explaining the increase in sunlit periods.

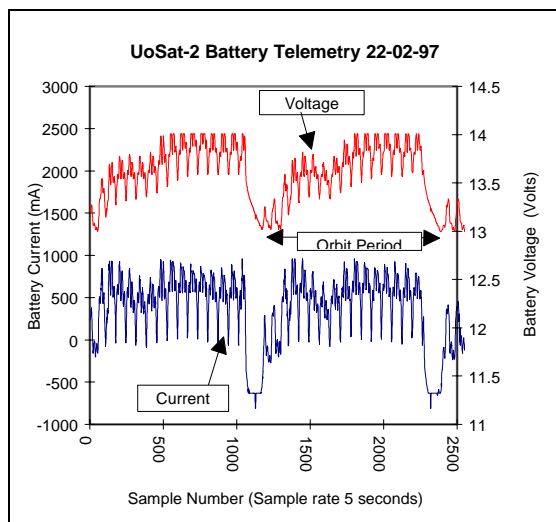

Figure 7.1 - UoSAT-2 Battery Telemetry

From the figure, it is interesting to note the somewhat 'spiky' voltage and current profiles. This is due to what is thought to be damage to one of the body mounted solar arrays during launch. As the spacecraft rotates the damaged solar array is illuminated approximately every 10 minutes, at which point the battery supplies the power to the spacecraft.

Unfortunately, as with all SSTL's in orbit spacecraft, it is not possible to perform capacity measurements, which would reveal a more informative picture of the health of the battery, as this operation is too risky considering that the battery is the only single point failure on the spacecraft

There are currently nine SSTL designed and manufactured satellites which are successfully using commercial cell batteries in low earth orbit, with a further six spacecraft awaiting launch in the near future. This equates to an impressive 60+ years of operations in LEO and over 300,000, in-orbit charge/discharge cycles without failure.

Figure 7.2 shows a breakdown of the number of charge/discharge cycles performed by the batteries on all of SSTL's in-orbit spacecraft.

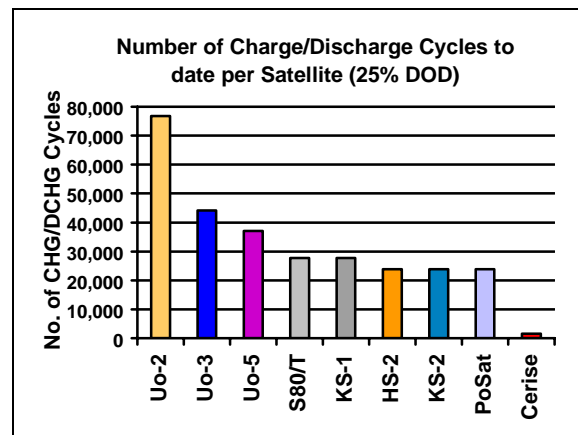

Figure 7.2: Breakdown of Charge/Discharge Cycles

In 1990, twin satellites, **UoSAT-3** and **UoSAT-4** were launched, but sadly UoSAT-4 failed after 36 hours of operation, due to what is thought to be a transmitter problem. UoSAT-3 is used for store and forward communications. **UoSAT-5** was produced to fly the experiments from the lost UoSAT-4, and was launched in 1991. **S-80/T** and **KITSAT-1** were both launched in 1992. S-80/T is an industrial research satellite, built by SSTL for CNES and Matra, while KITSAT-1 was Korea's first satellite, achieved via a technology transfer programme at SSTL. **POSAT-1** was Portugal's first satellite, also through a technology transfer programme and was launched in 1993, along with Korea's second microsatellite, **KITSAT-2**. **HealthSAT-2** is a store and forward communications satellite and enables isolated medical outposts to receive and send vital information around the globe. **Cerise** is a military research microsatellite, built for Alcatel and DME, and is the latest SSTL satellite to be launched successfully. The batteries on all spacecraft appear healthy and show no deterioration in performance.

Both S-80/T and Cerise have relatively high power payloads when compared to those normally flown on an SSTL microsatellite. During payload operations, the battery discharge current can be higher than 3 Amps, which, for a satellite with an orbital average power of 25 Watts, requires some careful operations planning. Payload operations on Cerise and S80/T have resulted in a more demanding charge/discharge regime for the battery. Even so, the increased demands of the battery performance have resulted in no detriment to the battery. In the case of S-80/T, this comes after over 6 years of in-orbit operations.

These figures become even more impressive when the spacecraft's orbit and thermal conditions are taken into account. Both S-80/T and KITSat-1 were together launched into a 1330km, 66° inclination orbit, by far the highest altitude orbit of all SSTL's microsattellites and, due to longer sunlit/eclipse periods and higher radiation environment, the most demanding on spacecraft hardware. The battery temperature on S80/T can sometimes fall as low as 0°C and climb to values of 35+°C, taking the battery to the extremes of it's specified operating temperature range. Yet, this seems to have resulted in no detriment to the battery's cycle life or characteristics, as can be seen from the data contained in Figure 7.3.

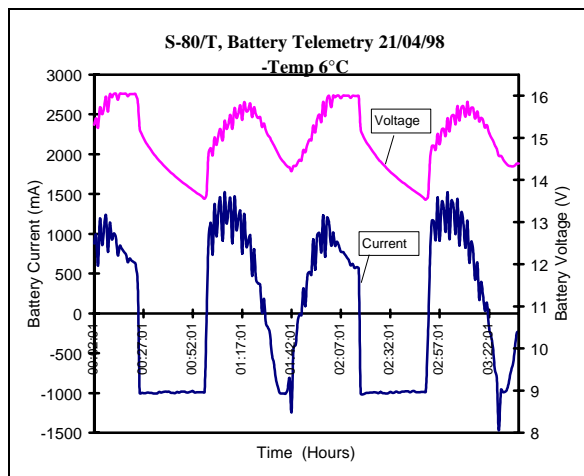

Figure 7.3 In Flight Data from S-80/T

Recent months have seen the payload on S-80/T unused, resulting in lower discharge currents and depth-of-discharge. The spacecraft has well outlived its mission requirements, enabling the customer to perform far more operations than they initially expected. From the data, which was downloaded recently, it is clear that the battery is still in very good health. During the eclipse period, the battery is discharged by approximately 20% of its capacity. The battery voltage is higher than a standard SSTL battery, and this is due to having 11 cells in series to meet payload requirements. It is clear, however, from the battery charge and discharge profiles, that the end of charge voltage, set by the BCR, is being reached with every orbit.

The dip in battery voltage and the absence of charge current from the BCR halfway through the sunlit period of the spacecraft's orbit, is due to passing over the equator. At this point, the gravity gradient boom (z-axis) of the satellite is pointing towards the sun (refer to Figure 5.2) resulting in little or no illumination of the solar arrays, which are mounted on the ±X and ±Y axes of the spacecraft.

Of course, with each day that passes, SSTL's spacecraft add a further 100+ battery charge /

discharge cycles to what is already a very impressive flight heritage of the commercial nickel cadmium spacecraft battery.

8. CONCLUSION

From the evidence presented in this paper, the commercial cell can be regarded as a genuine alternative to expensive space grade batteries without compromising mission reliability.

In an age when the production of military components steadily decreases, space companies are having to turn to qualifying commercial-off-the-shelf (COTS) components for use in spacecraft system. The processes that SSTL have employed to qualify commercial nickel cadmium cells, are an excellent example of how COTS can be successfully applied in a space application.

Pressure is also growing for the reduction of cost and length of space projects and it is only through means of cutting the delivery time and expense of long lead items, such as batteries, that cost and project length can be significantly reduced. This makes the use of a commercial cell battery, with delivery times as short as 2 months, a very attractive option for short life, low earth orbit missions.

9. ACKNOWLEDGEMENTS

The author would like to acknowledge the work of Nobuo Takeuchi and Carlos Lovett-Linares in the development the battery test programme, and also the efforts of the staff at Surrey Satellite Technology Ltd, and the University of Surrey, over the past 20 years of spacecraft design.

10. REFERENCES

- [1] GATES Energy Products, Sealed Rechargeable Batteries Application Manual.
- [2] SANYO CADNICA, Rechargeable Nickel Cadmium, Engineering Databook.
- [3] SANYO CADNICA, Sealed Type Nickel Cadmium Batteries, Engineering Handbook.
- [4] Willard R. Scott and Douglas W. Rusta, NASA Goddard Space Flight Centre, 'Sealed Cell Nickel-Cadmium Battery Applications Manual'.
- [5] H.S. Wong and M.J. Blewett, 'The UoSAT-2 Spacecraft Power System', Journal of the Institution of Electronic and Radio Engineers, Vol.57, No.5 September/October 1987.